

INSTALLATION AND OPERATING MANUAL

Diaphragm seal systems

MARCH 30, 2020

BADOTHERM

1 Contents

1.	Introduction.....	2
1.1	Regarding this manual.....	2
1.2	Terminology of components	3
1.3	Safe use of this product.....	4
1.4	Warranty.....	5
2	Handling and preparation	5
2.1	Storage	5
2.2	Unpacking the Diaphragm seal.....	6
2.3	Tagging	6
3	Installation.....	7
3.1	Precautions.....	7
3.2	Studbolts & Process Gaskets	8
3.2.1	Bolt torque.....	8
3.2.2	Gasket installation.....	8
3.3	Mounting the diaphragm seal	8
3.4	Mounting instruction for capillary.....	9
3.5	Fluid compatibility.....	9
3.6	Environmental conditions	9
4	Operation	10
4.1	Preparation of starting operation	10
4.2	Zero adjustment	10
4.3	Venting or draining.....	10
5	Maintenance.....	11
5.1	Periodic verifications	11
5.2	Cleaning.....	11
5.3	Disassembly instruction.....	12
5.4	Return of materials.....	12
5.5	Disposal of materials	13
5.6	Certifications	13

1. Introduction

This safety and installation guide contains important safety and handling information for Badotherm Diaphragm Seals and assemblies



CAUTION: Read this installation guide carefully before unpacking the diaphragm seal application. Improper handling can cause damage to the seal part, capillary or diaphragm. All diaphragm seal applications are tested and calibrated in a Badotherm factory under monitored and controlled conditions.

1.1 Regarding this manual

- This IOM should be provided to the end user.
- The contents of this IOM are subject to change without prior notice.
- All rights reserved. No part of this IOM may be reproduced in any form without Badotherm written permission.
- Badotherm makes no warranty of any kind with regard to this IOM, including, but not limited to, implied warranty of merchantability and fitness for a particular purpose.
- If any question arises or errors are found, or if any information is found to be missing from this IOM, please inform the nearest Badotherm sales office.
- The specifications covered by this IOM are limited to those for the standard type under the specified model number break-down and do not cover custom-made instruments.
- Please note that changes in the specifications, construction, or component parts of the instrument may not immediately be reflected in this IOM at the time of change, provided that postponement of revisions will not cause difficulty to the user from a functional or performance standpoint.
- Badotherm assumes no responsibility for this product except as stated in the warranty.
- If the customer or any third party is harmed by the use of this product, Badotherm assumes no responsibility for any such harm owing to any defects in the product which were not predictable, or for any indirect damages.
- The following safety symbols are used in this IOM:



Read IOM: ensure to read the manual before starting the mounting and operation.



Warning / Caution: Indicates potential hazard that could lead to (fatal) injuries or serious damage to the diaphragm seal system



Information: Attention for information that is essential for a proper functioning of the diaphragm seal system.



Important: Extra attention should be given for proper use of the diaphragm seal system.

1.2 Terminology of components

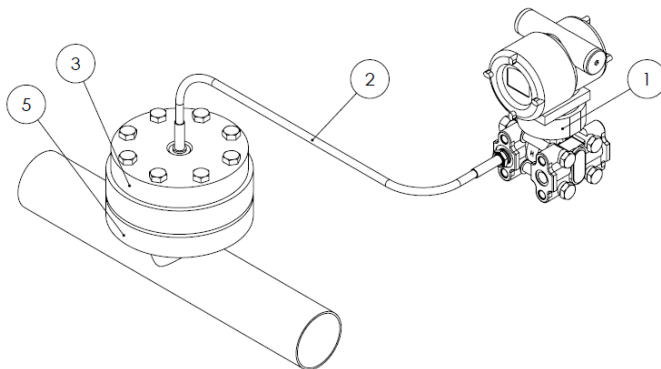

1	Transmitter
2	Capillary
3	Diaphragm seal (USL-F type shown)
4	Process flange

1.3 Safe use of this product

For safety of the operator, instrument and process installation please be sure to follow the manual's safety instruction. When not followed correctly Badotherm cannot guarantee proper and safe functioning of the diaphragm seal application.

POINTS OF ATTENTION

The diaphragm seal application may only be installed by an engineer or technician who is trained and has the required technical skill level and proper knowledge on diaphragm seals.

-When installing in high ambient temperature environments and process temperatures make sure not to burn yourself by touching the instruments, flanges and capillary lines.



-Never loosen bolts and plugs when the process is in operation. This can lead to serious injuries due to a sudden release of pressure or process fluid.

-When draining the instrument take necessary precautions to prevent inhalation or contact with harmful vapours or toxic process fluids.

-Make sure the process line is cleared by the process operator before working on the installation.

-Do not apply any modifications to the diaphragm seal assembly without consulting Badotherm sales office. Badotherm is not liable for any damage or malfunction as a result of modification.

1.4 Warranty

- The warranty shall cover the agreed period of warranty. Problems occurring during the warranty period shall basically be repaired conform the agreed conditions.
- If any problem is experienced with the application, Badotherm's affiliate from where the application is purchased, should be contacted
- When contacting Badotherm please share full details of the product such as serial number, type of seals, date of purchase and include as much as process data as available for a fast communication.
- The purchaser shall bear the responsibility for repair costs, even during the warranty period, if the malfunction is due to:
 - Improper and/or inadequate maintenance by the purchaser.
 - Malfunction or damage due to a failure to handle, use, or store the instrument in accordance with the design specifications.
 - Use of the product in question in a location not conforming to the standards specified by Badotherm, or due to improper maintenance of the installation location.
 - Failure or damage due to modification or repair by any party except Badotherm or an approved representative of Badotherm.
 - Malfunction or damage from improper relocation of the product in question after delivery.
 - Reason of force majeure such as fires, earthquakes, storms/floods, thunder/lightening, or other natural disasters, or disturbances, riots, warfare, or radioactive contamination.

2 Handling and preparation

2.1 Storage

Storage of the diaphragm seal application should be in its original packing including diaphragm protection. The storage area should be selected in line with below conditions:

- Not exposed to rain or water leaks.
- Minimal vibrations and shocks
- Ambient temperature
 - -40°C... 85°C without local indicator (check individual transmitter specification)
 - -30°C ...80°C with local indicator (check individual transmitter specification)
- Relative humidity 0%...100% R.H. (@40°C)
- Preferred environment 25°C at 65% R.H.
- When diaphragm seal application is used clean and rinse it thoroughly before putting it back in store. Protect the diaphragms at all times and wind the capillary and secure it with a ty-wrap.

2.2 Unpacking the Diaphragm seal



CAUTION! *Damage to diaphragm seal systems can lead to inaccuracies of the measurement or permanent damage to the system. Fill fluid can escape from the system. Extra caution should be taken to protect the diaphragm and the capillary from damage.*

- To protect the measuring system from mechanical damage leave it in the factory packing until reaching the installation site.
- Remove the diaphragm protection just prior to installing the diaphragm seal on the process.
- Never lift the diaphragm seal lifting or gripping it by the capillary and avoid twisting and bending radius <150mm (6") under all circumstances
- Support both the diaphragm seal lower part(s) and measuring instrument when lifting it from the box.
- Make sure the surface is free of dirt, debris, and fluids that may damage the diaphragm before putting the application down. A damaged diaphragm will cause inaccuracies and/or failure of the chemical seal application.
- NEVER attempt to disconnect the seal part from the pressure instrument. This results in loss of fill fluid and the seal combination will not perform properly and will void the product warranty.

2.3 Tagging

Each instrument is tagged with important material and fluid information. The information present on the instrument is:

- Production date
- Badotherm tracking number
- Tag. No. (if applicable)
- Span
- Filling fluid
- Diaphragm material



INFORMATIVE: *When contacting Badotherm regional centres send the above details along in the correspondence for a fast response and action plan.*

3 Installation

3.1 Precautions

Only qualified persons authorised by the plant manager are permitted to install, maintain and service the diaphragm seal. Before installation check the process specifications with product specifications. For installation use appropriate fixing position, screws and screw nut according to fitting, and flange standard.

POINTS OF ATTENTION



- *Welding near the diaphragm seal system can give damages to the application. Prevent welding currents to run through the diaphragm seal systems and do not use capillary for grounding.*
 - *Do not use the diaphragm seal, the capillary or transmitter as a support for climbing the installation. This can lead to permanent damage.*
 - *Never loosen bolts of the transmitter cover flange or the filler screw. This will cause leakage of fill fluid and give permanent damage to the application.*
-

3.2 Studbolts & Process Gaskets

Studbolts and gaskets are not in the scope of the supply of Badotherm. The selection and use of the gaskets and studbolts is the sole responsibility of the end user. Gaskets inside diameter should be greater than the start of the gasket surface dimension “G” on the datasheets. This will prevent damage to the diaphragm seal and blocking of process media. When mounting the BRF raised face covered diaphragm seal extra care should be taken with the use of spiral wound gaskets. With high torques the gasket can damage the raised face covering foil.

Studbolts can be selected in a wide variety of materials depending on the conditions they are used. The length of the studbolt is depending on the thickness of flange, type of holes (open holes or threaded holes), accessories used (flush / drip rings) and the process it is installed.

3.2.1 Bolt torque

The bolts should be tightened with the appropriate torque to the applicable flange/gasket requirements. Required torque is a function of flange size and rating gasket material and the bolts and nuts used.

3.2.2 Gasket installation

The gasket should be applicable for the maximum required pressure and process conditions and make sure the gasket is properly aligned on the gasket sealing surface, not covering any part of the diaphragm portion. Do not use hard gaskets in combination with raised face covered seal parts



WARNING: Failure to follow these safety instructions could result in injury or other damage. Badotherm refutes all responsibility for any direct or indirect damage to property or persons resulting from failure to follow the instruction in this guide.

3.3 Mounting the diaphragm seal

When mounting differential pressure diaphragm seals it is important to correctly the “H” and the “L” side of the diaphragm seal. The H-side and the L-side are clearly marked on the transmitter capsule. The high pressure side is mounted on the bottom nozzle of the installation, the low pressure side is mounted on the top side of the installation. When there is only 1 side mounted with diaphragm seal the other side of the transmitter can be equipped with an impulse line / wet leg. This type of systems are not preferred when using diaphragm seals. When diaphragm seals are mounted on both sides the negative influence of impulse lines such as condensate, freezing, environmental contamination, different temperature expansion effect, is eliminated.

3.4 Mounting instruction for capillary

Capillary should be handled with care. Points of attention when installing the diaphragm seal applications with capillary are:

- The capillary should never be bent with a smaller radius than 150mm (6"). Smaller radii can lead to rupture and reduce of strength. When handling a device, the capillary must never be bent.
- Surplus capillary must be wound and bundled with a diameter >150mm (6 inch).
- Fix all capillary so it is free of vibration or movement. This to prevent signal deviations.
- When choosing the location to fix the capillary, take into account any direct sunlight, (cold) winds, big differences between H and L side in case of DP systems. These influence the accuracy of the measurement.

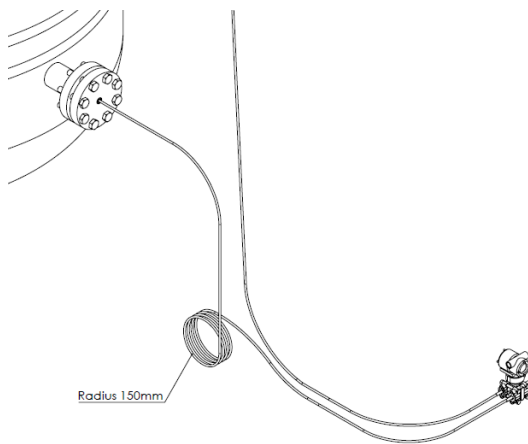

3.5 Fluid compatibility

Before installing the diaphragm seal, the material/process fluid compatibility must be checked. The latest information on material compatibility can be found in the tables at: www.badotherm.com/downloads/Badotherm_seal_filling_fluid_overview.pdf

3.6 Environmental conditions

The condition of the local environment of the diaphragm seal gauge must be analysed carefully when installing the diaphragm seal system. The frequency of the vibration and the surrounding atmosphere must be observed. The frequency limits are denominated in the table below. For environments where the gauge is exposed to high frequency vibrations a temperature gauge with a capillary is necessary. The surrounding atmosphere must be free of heavily corrosive gasses to prevent corrosion of the materials used in the temperature gauge. The ambient temperature where the diaphragm seal with transmitter is located should be below 80°C for proper functioning of the pressure transmitter.

Nozzle load – Nozzle load should be taken into account when mounting diaphragm seal assemblies. The weight of the diaphragm seal construction can be calculated with datasheets or observed on commercial drawings.

4 Operation

The general safety of a facility often depends on the reliability of indications of the diaphragm seal system. Any system that seems to be giving false readings must be taken out of service immediately, and then tested with a testing device. If the tests prove the reading is unreliable, it must be replaced by a new diaphragm seal system.

4.1 Preparation of starting operation

Before starting the process it is important to check and prepare the diaphragm seal assembly after it is installed. Check the following:

- Confirm there is no leakage between the diaphragm seal and the process flange.
- Check if the instrument valves, vent and drain plugs are closed
- Confirm that the power supply is mounted to the correct terminals.
- Check if the transmitter is mounted in line with type of pressure that measured. Eg: in case of vacuum transmitter should be mounted >30cm below the nozzle.

4.2 Zero adjustment

Due to the installation of diaphragm seals to the pressure transmitter it is likely that after the transmitter is mounted a small deviation is observed. This mounting effect can be simply zeroed out so the 4mA point will be actual installed value. Beware that the transmitter has a maximum allowed zero adjustment (eg: 3% of the Upper Sensor Limit). Zero adjustment can be executed in two ways depending on the type of transmitter:

1. By means of a zero adjustment screw on the transmitter head. Check the transmitter manual for the exact location and operating instructions.
2. By means of a communicator. Depending on the type of communicator the zero adjustment can be executed directly on the powered transmitter terminals. Check the specific transmitter and communicator manuals for the instructions.

4.3 Venting or draining

When the diaphragm seal is equipped with a vent or drain by means of a lower part or flush assembly it is possible to perform this operation. When starting the operation it is possible to remove the air bubble trapped in dead areas by opening the instrument valve on the top side. When removing the diaphragm seal from the installation it is possible to drain the dead areas in the diaphragm seal. However both venting and draining should be done with care and in line with the local regulation. It is possible that toxic gasses or aggressive process media is released in the open environment. It is advised to attach the vent and drain ports to a central installation to catch the gasses and fluids from the process.



WARNING: Harmful process media and gases can be accumulated. Take appropriate precaution to avoid contact with the body or inhalation. Use safety clothes, protective goggles and protective (chemical resistant) gloves before starting the disassembly.

5 Maintenance

Diaphragm seals are free of maintenance when used and installed correctly. However it is advised to perform checks on a regular basis to ensure the measurement accuracy is in line with the expectations and trends are OK.

5.1 Periodic verifications

Depending on the plant guidelines it is advised to perform a check once year. Points of attentions are:

- Visual check on all potential leakage points. Sign of leakage detected in an early stage can prevent major incidents or permanent damage to the diaphragm seal.
- Check on torque of the process bolts and the retaining bolts.
- Stable reading of the output signal by comparing trendlines.
- Electrical wiring damage of the pressure transmitter.
- Any abnormal condition should be reported.

5.2 Cleaning

The diaphragm seal is not required to be cleaned from the outside. However keeping the instrument clean and tidy would increase visibility of leakages in an early stage. The diaphragm itself can be necessary to clean when it is installed on contaminated, viscous or crystallising media. Only remove dirt and deposits with a soft cloth with a suitable solvent. Removing contaminations with hard tools will damage facing and diaphragm.

5.3 Disassembly instruction

For safe disassembly of the diaphragm seal the following steps must be carried out sequential:

1. Shut down the process or close the valve.
2. Check if the diaphragm seal has an acceptable temperature and to prevent burning.
3. Check if the process is de-pressurized and is not containing hazardous process fluid that can be released when removing the seal.
4. Remove the power supply cabling from the transmitter
5. Un-tighten the diaphragm seal with a correct sized spanner.
6. Check if the diaphragm seal is clear from process residues which may cause damage to persons and the environment.
7. Put a cover on the flange to protect the diaphragm from damaging
8. When sending the diaphragm seal to a Badotherm office, clean the process parts, pack it safely, and attach a proof of cleanliness.
9. When disposing the diaphragm seal please observe the local waste treatment and disposal regulation.

CAUTION:

- When working on the installation take appropriate safety measures according plant regulations.
- Make sure all instruction are followed and the instrument is depressurized and within a safe handling temperature.
- Before venting and draining check if the process media is safe for handling or safety pre-cautions are in place.
- Mishandling products exposed to a hazardous substance can cause serious injury



5.4 Return of materials

When returning materials back to Badotherm that have been installed the instruments should be cleaned and packed in a proper way. The products should be free of contamination and accompanied by a SDS, cleaning confirmation, and pre-cautionary instructions for Badotherm service employees.

WARNING: Mishandling products exposed to a hazardous substance can cause serious injury or death. If the product is exposed to a hazardous substance a copy of the Material Safety Data Sheet (SDS) must attached to the returned goods. Materials where no proper documentation is found and there is a doubt of health and safety will be quarantined and investigated by local health authorities. All cost will be projected on the owner of the instrument.



5.5 Disposal of materials

Disposal of diaphragm seals and packing materials should be done with care. Diaphragm seals from process installation can carry contaminations that can harm the environment. Dispose the materials in line with the country specific waste disposal regulations. It is always good to split the different materials by sort so they can be recycled in an easy and friendly way.

5.6 Certifications

Diaphragm seals made by Badotherm are subjected to all kind of regulations, guidelines, international standards, and customer specific demands. Next to the demands mentioned in the international flange standards Badotherm Diaphragm Seal Systems are having a conformity certificate for the “*Pressure Equipment Directive*” (PED) 2014/68/EU, and the is certified for the ISO 3834-2 “*Quality requirements for fusion welding of metallic materials*”



EU CERTIFICATE OF CONFORMITY

In accordance with the requirements of the Pressure Equipment Directive 2014/68/EU and the Pressure Equipment (Safety) Regulations 2016, UK Statutory Instrument 2016 No. 1105

This is to certify that the Quality Management System of:

Badotherm Proces Instrumentatie B.V.
Kelvinstraat 13
3316 GM Dordrecht
The Netherlands

has been assessed against the requirements of Annex III, Module D1 of the Pressure Equipment Directive 2014/68/EU and Schedule 4, Module D1 of The Pressure Equipment (Safety) Regulations 2016 and conforms to the requirements for the products shown below:

Diaphragm seals, diaphragm seal systems and flush accessories for the process instrumentation.

Approval is subject to the continued maintenance of the quality system in accordance with the requirements of the above Directive and Regulations.

Authorisation is hereby given to use the LRV Notified Body Identification Number in accordance with the requirements of the specified Directive and Regulations in relation to the products as identified above.

Certificate Approval No: 0038/PED/RQA00020490
Original Approval: 24 May 2019
Current Certificate: 24 May 2019
Certificate Expiry: 23 May 2022

LRV Notified Body Number 0038



L.H.M.W. Fok, Senior Administrator Staff,
on behalf of Lloyd's Register Verification

Lloyd's Register Verification Limited, Registered Office 71 Fenchurch Street, London EC3M 4BS UK. A Subsidiary of Lloyd's Register Group Limited

Lloyd's Register Group Limited, its affiliates and subsidiaries, including Lloyd's Register Quality Assurance (LRQA), and their respective officers, employees or agents are, individually and collectively, referred to in this clause as 'Lloyd's Register'. Lloyd's Register assumes no responsibility and shall not be liable for any person for any loss, damage or expense caused by reliance on the information or advice in this document or otherwise provided, unless that person has agreed a contract with the relevant Lloyd's Register entity for the provision of this information or advice and in that case any responsibility or liability is exclusively on the terms and conditions set out in that contract.



Certificate

Lloyd's Register Quality Assurance hereby certifies that the company:

Badotherm Proces Instrumentatie B.V.
Kelvinstraat 13, 3316 GM Dordrecht, The Netherlands

has furnished proof to fulfil the quality requirements for welding according to:

ISO 3834 – 2 : 2005
Quality requirements for fusion welding of metallic materials –
Part 2: Comprehensive quality requirements

in the extent mentioned on the schedule of this certificate.



P.G. Cornelissen - Area Manager North Europe
Issued by: Lloyd's Register Nederland B.V.

This certificate is valid only in association with the certificate schedule bearing the same number

Current issue date: 24 May 2019
Original approval date: 24 May 2019
Expiry date: 23 May 2024
Certificate number: 00669459
Approval number(s): 00020489



Lloyd's Register Group Limited, its affiliates and subsidiaries, including Lloyd's Register Quality Assurance (LRQA), and their respective officers, employees or agents are, individually and collectively, referred to in this clause as 'Lloyd's Register'. Lloyd's Register assumes no responsibility and shall not be liable for any person for any loss, damage or expense caused by reliance on the information or advice in this document or otherwise provided, unless that person has agreed a contract with the relevant Lloyd's Register entity for the provision of this information or advice and in that case any responsibility or liability is exclusively on the terms and conditions set out in that contract.